

STAGE V
CERTIFIED



Heavy IC Forklift Truck

with capacities of 14,000 to 18,000kg



ZHEJIANG HANGCHA IMP. & EXP. CO., LTD.

Factory site: 666 Xiangfu Road,
Hangzhou, Zhejiang, China (311305)

Tel: +86-571-88926735 88926755
Fax: +86-571-88926789 88132890

sales@hcforklift.com
www.hcforklift.com



Follow us on
Facebook



Follow us on
YouTube



Follow us on
WeChat



ISO14001
ISO14001:2015



ISO9001
ISO9001:2015



HANGCHA trucks conform
to the European Safety
Requirements.

2020 VERSION 1 / COPYRIGHT 2020/01

HANGCHA GROUP CO., LTD. reserves the right to make any changes without notice concerning colors, equipment, or specifications detailed in this brochure, or to discontinue individual models. The colors of trucks, delivered may differ slightly from those in brochures.

The World of Hangcha



Heavy IC Forklift Truck

Environment/
Efficiency/
Economy



STAGE V & TIER 4F

HANGCHA with you at every stage

Efficient, reliable solutions for your demands

With Hangcha you can meet all Stage V/Tier 4f emissions standards which provides customer demands for value, innovation and performance. The technologies include common rail fuel systems, Turbocharged Inter-cooled selective catalytic reduction (SCR), diesel oxidation catalysts (DOC) and diesel particulate filters (DPF). Designed and optimised to every engine model, our forklift truck maximises efficiency and reliability.

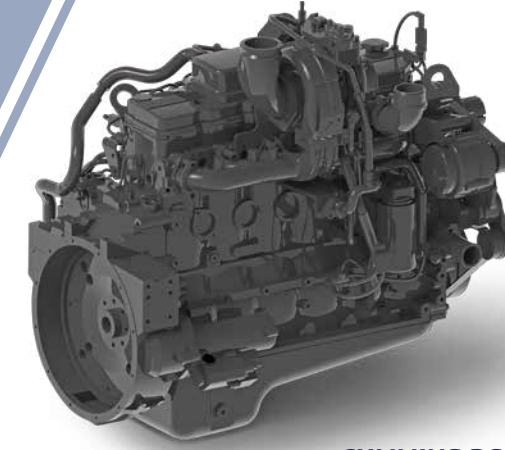

CUMMINS B6.7

Hydraulic System

/ The main hydraulic components like the control valves, variable pump are products of Rexroth.

Transmission System

/ ZF micro controller with 3 stage power-shift is to make sure the high reliability. German Kessler heavy load drive axle, with two stage speed adjust, multi-disc wet service brake system, is fully enclosed system with maintenance free.

Steering System

/ Transverse steering axle with full hydraulic steering and sensor system is to make sure easy steering.



Cabin

/ Tilting cabin is easy to daily service, and the wide view mast, high positioned seat provide good front visibility to operator.

Standard Specification

- | | |
|------------------------------|------------------------------------|
| / Heater and air conditioner | / Pre-heat indication |
| / Hour meter | / Wide view duplex mast |
| / Bracket of light | / 4 Sec. multi-way valve |
| / Cabin | / Hydraulic power steering |
| / Traction pin | / Rubber pedal |
| / Headlight | / Dipstick |
| / Horn | / Air cleaner |
| / Mirror | / Adjustable steering wheel |
| / Toolbox | / Tilt cylinder self-locking valve |
| / Forks | / Side roller |
| / Charge indicator | / Mast lift speed limited valve |
| / Combination rear light | |

Options

- / 2.5-6.0m duplex mast
- / Special carriage and backrest
- / Solid tyre
- / Other dimension forks
- / Other attachment
- / Fire extinguisher
- / Suspension seat
- / Dual air cleaner or special air cleaner
- / Rear working light
- / Customer painting

